

Potash

Fertilizer Industry



Potash products

GEA Messo PT, with its expertise in evaporation and crystallization has developed and successfully installed numerous processes in the field of Potash for fertilizer applications.

That covers:

Common name	Chemical name	Formula
Muriate of potash	Potassium chloride	KCl
Nitrate of potash or salpeter	Potassium nitrate	KNO ₃

Potassium chloride from sylvinit

Multiple flash cooling crystallization plants are used to recover pure crystallized Potassium chloride from brine containing KCl and NaCl. Quality targets are the K₂O content a particle size of up to 1.2 mm. DTB crystallizers are used. Heat recovery is important for saving energy.

The graphic shows a typical process for a multi-stage flash-cooling crystallization.

- Multi-stage flash-cooling crystallization in DTBs
- Temperature drop from 110°C to 45°C
- Heat recovery in e.g. 4 stages
- Condensation in 3 re-cooling stages

K₂O content selectable by remixing condensate, e.g. between 62 and 58%.

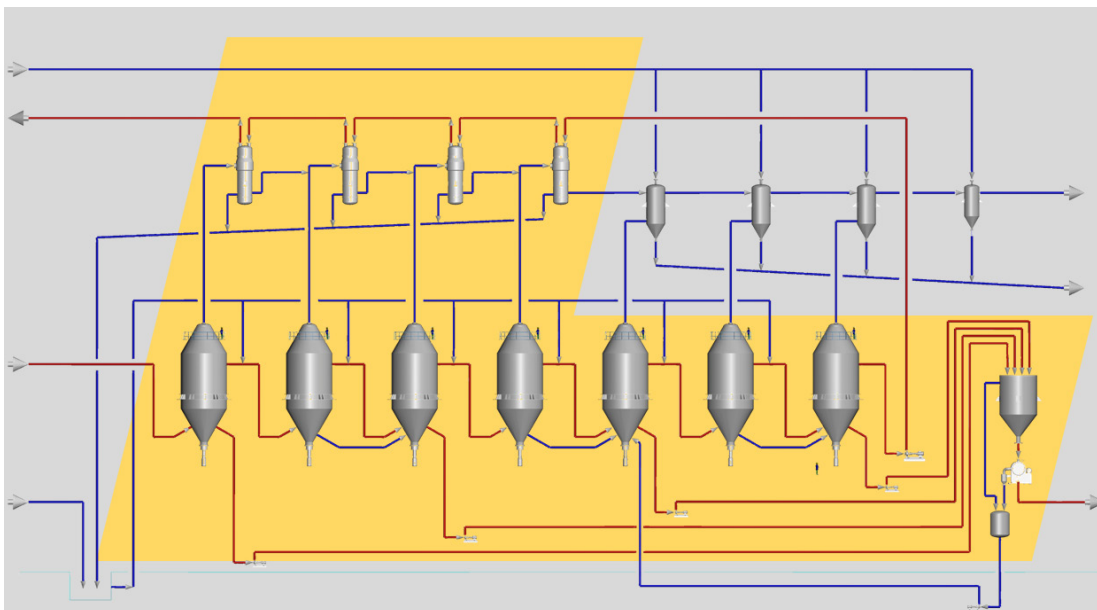

Multi-stage flash-cooling crystallization of KCl in fertilizer grade

Potassium chloride from carnallite

Plant supplied for the recovery of Potassium chloride from 1,000,000 m³/year Carnallitic tail liquor to produce high concentrated MgCl₂ brine of 500,000 mt/year.

If processing Potassium chloride from Carnallitic ores containing typically KCl, MgCl₂, NaCl, MgSO₄, and CaSO₄, additional purification steps must be provided to achieve the required product quality and the yield for economical operation. The process is an always a tailor-made design adapted to the individual conditions of the feed solution and the availability of utilities.

GEA Messo PT operates their own development center to accompany the process design with lab investigations and process simulations in mini plants.

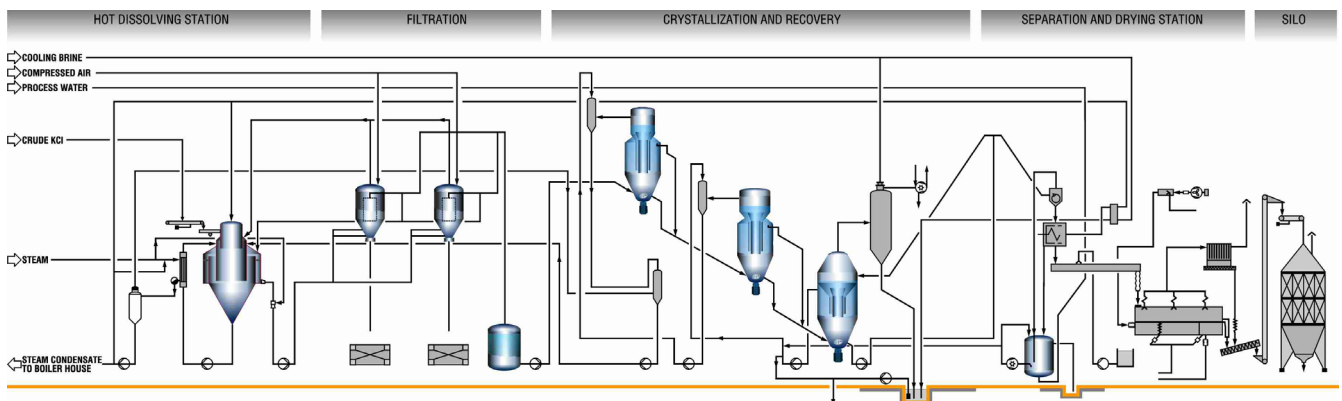

Recrystallization of drier dust in industrial grade quality - Middle East



Direct conversion crystallization of KNO₃

Potassium nitrate from caliche

Potassium nitrate produced by conversion using crude sodium nitrate as a natural product and fertilizer grade Potassium chloride:

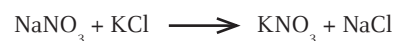

The direct conversion crystallization of KNO₃ is an innovative design by GEA Messo PT saving one entire factory for the rectification of Sodium nitrate before the conversion.

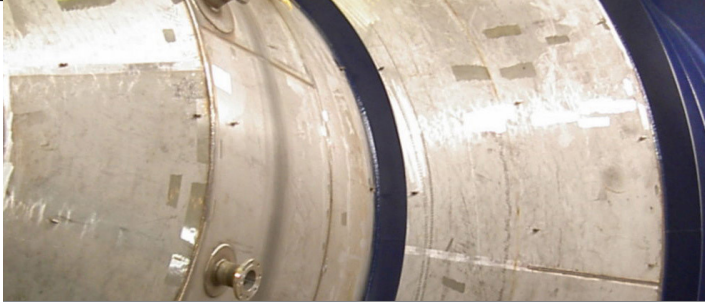

Contact us at:

www.gea-messo-pt.com



Process Engineering

GEA Messo PT

Germany:

Friedrich-Ebert-Strasse 134
47229 Duisburg
Tel. +49 2065-903 0, Fax +49 2065-903 199
info.geamesso.de@geagroup.com

The Netherlands:

De Beverspijken 7b
5221 EE 's-Hertogenbosch
Tel. +31 73 6390 390, Fax +31 73 6312 349
sales.niropt.nl@geagroup.com